

NOTE: The MB-C10 and the C-10SW are sold separately so that they may be purchased and installed during different phases of construction.

### MB-C10 PACKAGE CONTENTS

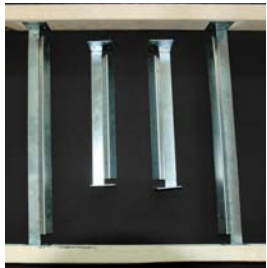

Two (2) pairs of steel mounting rails

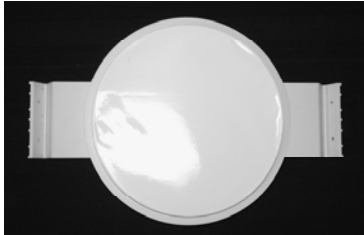

Eight (8) short screws (Item 1) and eight (8) longer screws (Item 2)

### C-10SW PACKAGE CONTENTS



Speaker Mounting Handle



Grille Removal Tool



Four (4) Speaker Mounting Screws

\*Grille also included, but not shown

## C-10SW & MB-C10 In-Ceiling Subwoofer System

### Installation Guide

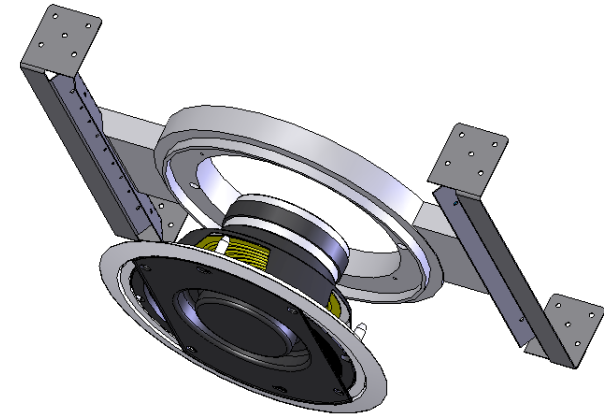

*The MB-C10 combination mounting & pre-construction bracket and the C-10SW 10" woofer assembly are packaged and sold separately. These instructions accompany both.*

The MB-C10 & C-10SW In-Ceiling Subwoofer system has been designed to mount directly to 16" OC, 19.2" OC & 24" OC wooden frame construction members (ceiling joists and trusses).

The integrated system weighs approximately 11 pounds, which is much too heavy to be suspended overhead in sheetrock especially when you take into consideration the punishing excursions the 10" long-throw woofer is capable of.

For the sake of safety, the system is designed such that the entire assembly is mounted directly to the structure's framing members. It actually re-enforces the sheetrock by unitizing it, the assembly and the structure's framing together.

Primarily designed for "new construction", in some cases it may also be retro-fitted into existing construction, which is to say, after the sheetrock is in place. This may be accomplished when access to the "other side" may be gained. The structural mounting bracket may be installed from above the sheetrock.

**OEM Systems Co., Inc.**

740 Freeport Boulevard, Suite 106, Sparks, NV 89431 (775) 355-0405

[www.oemsystems.com](http://www.oemsystems.com)

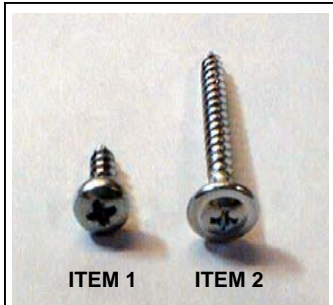

**Figure 1**  
The MB-C10 mounting bracket contains eight (8) short screws (Item 1) and eight (8) longer screws (Item 2).

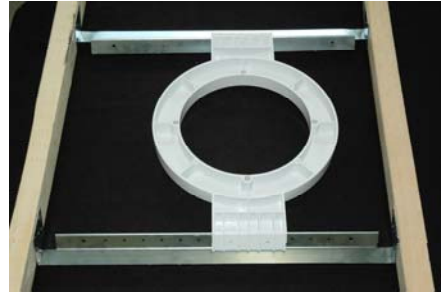

**Figure 2**

### INSTALLATION OF MB-C10

The MB-C10 consists of five separate pieces and two different types of screws. There are two pairs of steel mounting rails supplied. One pair 14.5" long to span 16" OC members and one pair 22.5" long to span 24" OC members. These fasten to the framing members with screws (Item 2) as shown in Figure 2. The appropriately sized set of rails for 19.2 OC framing is available separately (MBR-192).

Mount the white plastic bracket to the appropriate set of rails with the shorter screws (Item 1 in Figure 1). Place the white plastic bracket in the middle position and tighten the screws.

Put the assembly in position between the rafters and fasten with the longer screws (Item 2 in Figure 1). Make sure that the room-side of the rails are flush with the rafters.

Now that the steel mounting rails are fastened to the rafters and spaced properly, the position of the mounting bracket along the rails can be adjusted. When used with 24" OC framing members there is considerable space to slide the round plastic mounting frame back & forth on the rails to the desired location; installations into 16" OC provide little space for adjustment.

Leave the white film that covers the mounting opening in place until you are ready to install the C-10SW.

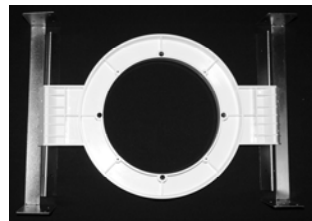

### INSTALLATION OF C-10SW

Remove the grille with the included Grille Removal Tool. Cut the white film out of the mounting bracket with a utility knife.

Connect the speaker wires and place the C-10SW up into the ceiling by holding the black steel installation handle. Use the guides shown below in Figure 3 to align the speaker frame with the mounting bracket.

Attach the speaker to the mounting bracket with the four black screws that are included with the C-10SW.

Remove the installation handle by loosening the two screws that hold it in place and turning it so that the screw heads pass through the keyhole openings.

Tighten the two screws that held the handle in place.

Attach the grille with spun cellulose insert. The white insert goes between the driver and the grille to improve the appearance.

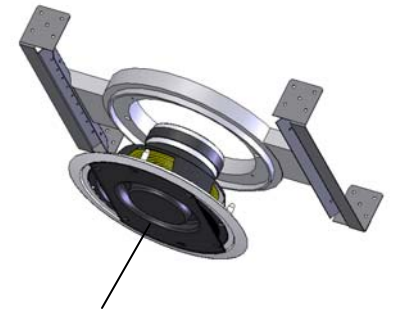

**CAUTION: THIS INSTALLATION HANDLE MUST BE REMOVED BEFORE THE SUB IS ACTIVATED**



**Figure 3**

